

ELITE ACOUSTICS ENGINEERING INC.
STOMPMIX 4-2 PLUS

IMPEDENCE:
 CHAN 1/2 INPUT XLR - 1K OHM
 CHAN 1/2 INPUT TRS - 10K OHM
 CHAN 1/2 INSTR - TS - 1M OHM

CHAN 3/4 - TS - 1M OHM
 OUTPUT 1 XLR - 150 OHM
 OUTPUT2 TRS - 150 OHM.

FREQUENCY RESPONSE:
 20Hz - 19KHZ +/- 1db

XLR MIC GAIN - about 60dbu
 CHAN 1/2 TRS GAIN - about 30dbu
 CHAN 3/4 TS GAIN - about 20dbu

REVERB is ONLY MAIN MIX
 REVERB is ONLY in STEREO

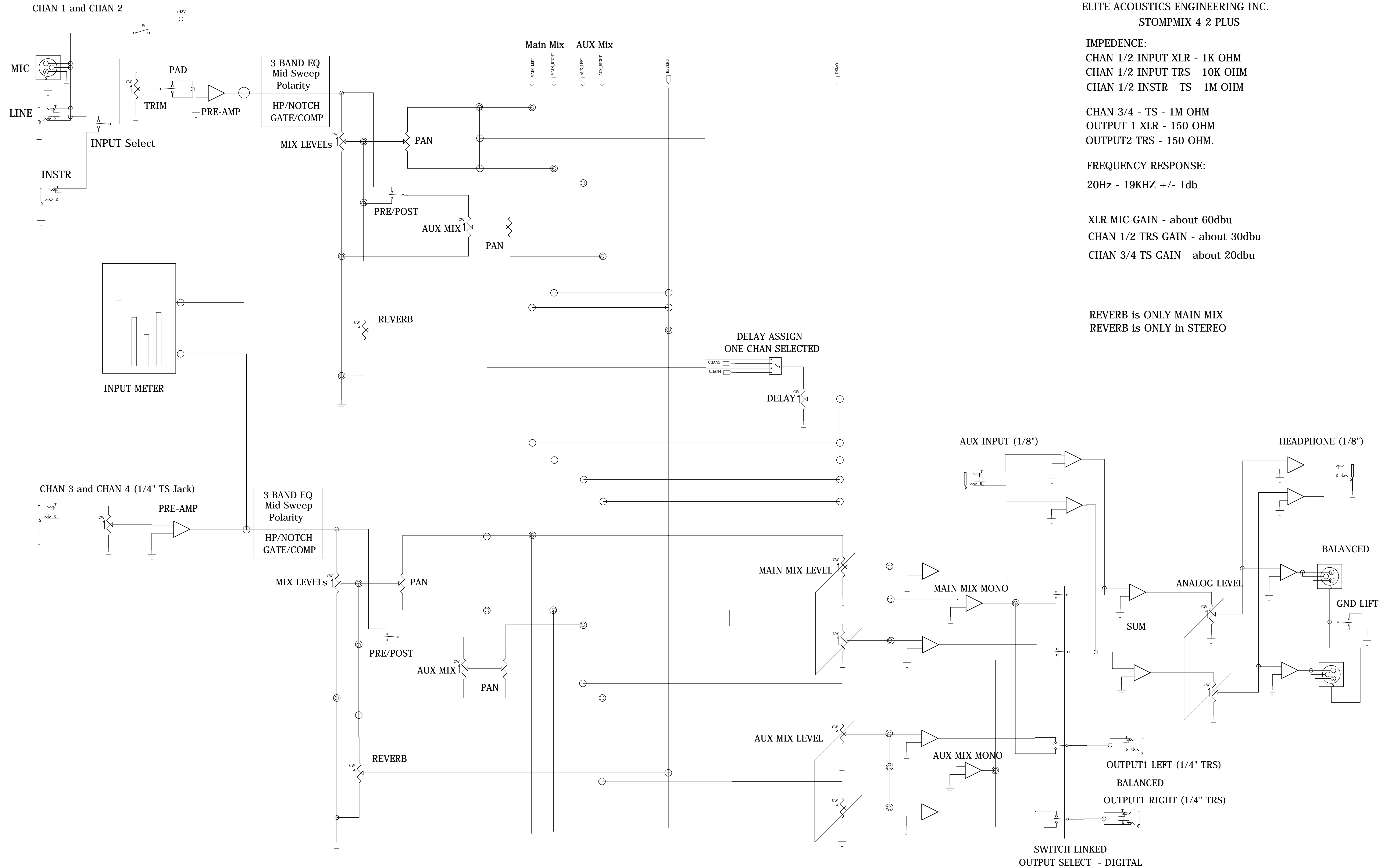

SWITCH LINKED
 OUTPUT SELECT - DIGITAL